

3-2 Configurazioni previste

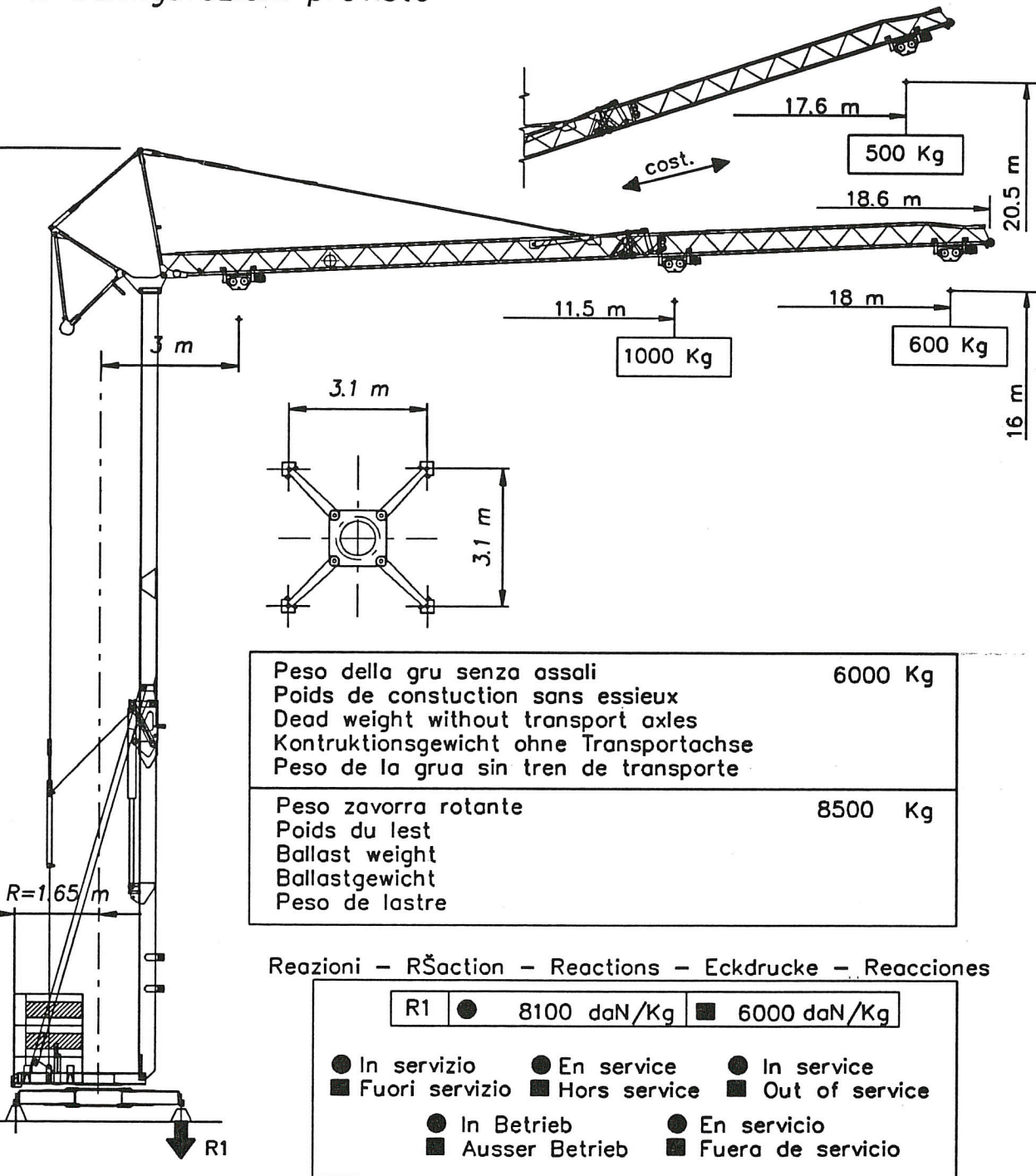

Curve di carico - Courbes de charges - Load diagrams - LastKurven - Curvas de cargas

Braccio impennato - FlŠche relevŠe - Luffing jib - Ausleger in steilstellung - Flecha izada

Versione trifase 500 Kg cost. - Versione monofase 400 Kg cost.

12 14 16

m

3-2 Configurazioni previste

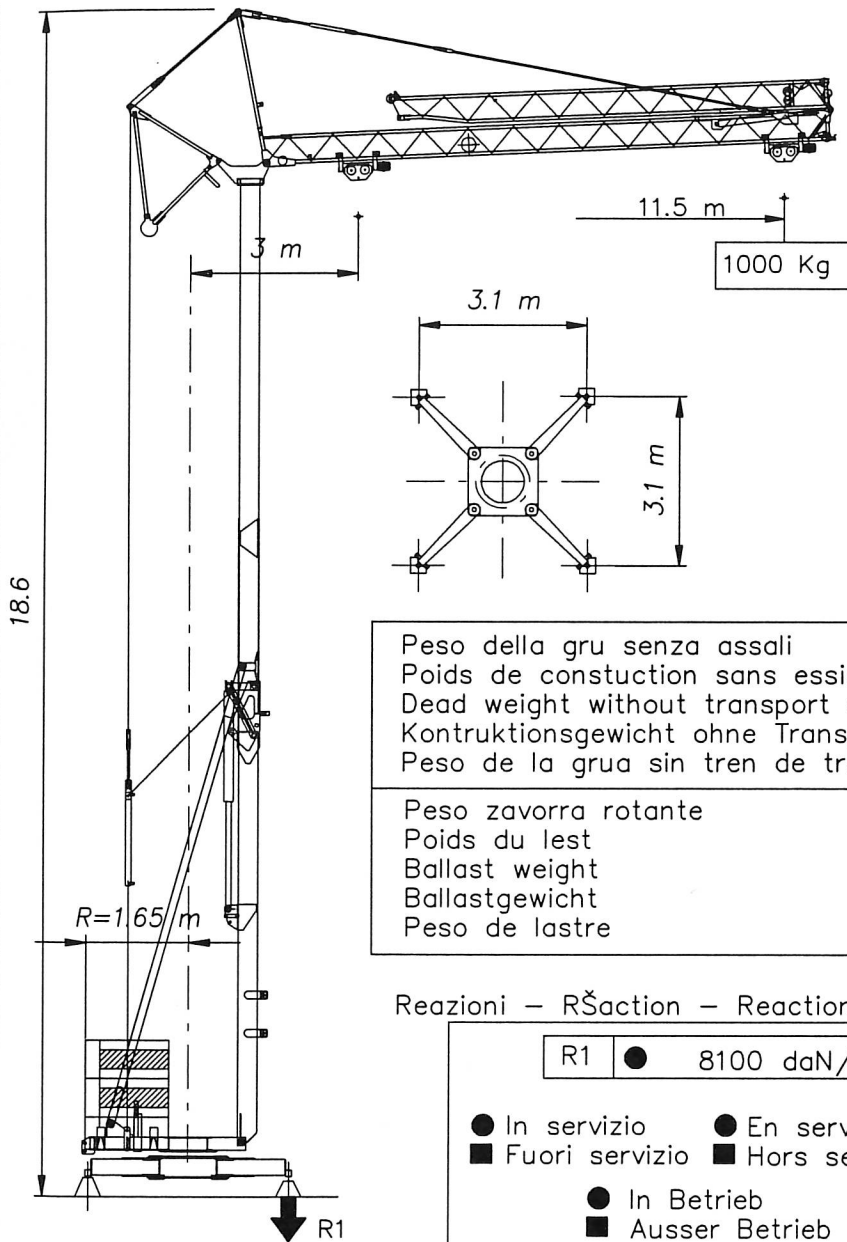

Peso della gru senza assali	6000 Kg
Poids de construction sans essieux	
Dead weight without transport axles	
Konstruktionsgewicht ohne Transportachse	
Peso de la gru sin tren de transporte	

Peso zavorra rotante	8500 Kg
Poids du lest	
Ballast weight	
Ballastgewicht	
Peso de lastre	

 Reazioni - R^šaction - Reactions - Eckdrucke - Reacciones

R1	●	8100 daN/Kg	■	6000 daN/Kg
----	---	-------------	---	-------------

● In servizio	● En service	● In service
■ Fuori servizio	■ Hors service	■ Out of service
● In Betrieb	● En servicio	
■ Ausser Betrieb	■ Fuera de servicio	

Curve di carico - Courbes de charges - Load diagrams - LastKurven - Curvas de cargas

	Braccio impennato - FIšche relevše - Luffing jib - Ausleger in steilstellung - Flecha izada				
	Versione trifase 500 Kg cost. - Versione monotrifase 400 Kg cost.				
	<table border="1"> <tr> <td>11.5</td> <td>m</td> </tr> <tr> <td>1000</td> <td>Kg</td> </tr> </table>	11.5	m	1000	Kg
11.5	m				
1000	Kg				